

# Boat Hoist USA

## General information and guides for installing a hoist lift system onto an existing overhead structure.

Structures built on the water vary depending on the geographic location. Below represent 6 of the most common construction methods used in stationary dock construction. Identify the closest resemblance to your structure and proceed to that page for further information and design of the lift.

### Wood Construction Using 3 Overhead Joists

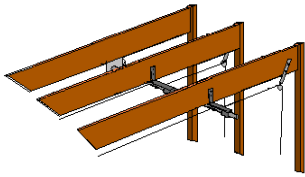

A common construction method where the boat house has two joist that are larger or doubled to carry the weight of the boat. A third joist is required to hang the hoist.

**Recommended installation for boats up to 8,500 lbs straight line.**

### Wood Construction With No Dedicated Lifting Joists

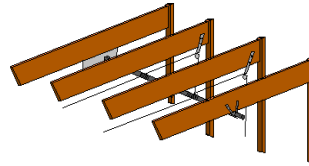

A common construction method where the structure does not have two larger or doubled joists for the lift, but has standard 2x6 or 2x8 floor joists at 16" to 24" centers. The installer uses as many joists as needed.

**Recommended installation for boats up to 8,500 lbs straight line.**

### Wood Construction With Twin Motors For Boats Exceeding 8500 lbs

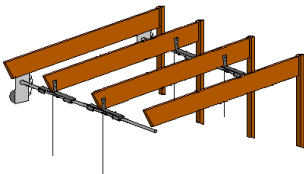

Installing two independent hoists on a wood structure allowing to straight line lift boats exceeding 8500 lbs.

**Recommended installation for boats exceeding 8,500 lbs.**

### Wood Construction Using 3 Overhead Joists With Hoist & Pipe Mounted To One Side

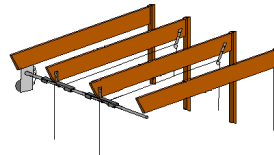

Recommended for boats weighing up to 4500 lbs only.

**Not recommended for boats weighing more than 4,500 lbs.**

### Steel Top Structure On 4 Pilings Using 2 Cross Beams For The Lift

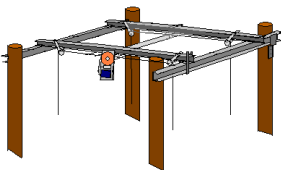

The upper structure consists of steel I-beams, tubing or channels with at least two beams running perpendicular over the slip.

**Recommended installation for boats up to 8,500 lbs straight line.**

### Steel Top Structure On 4 Pilings Using 2 Cross Beams for Twin Motors

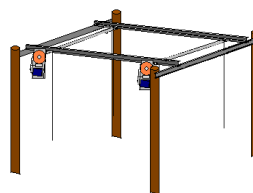

The upper structure consists of steel I-beams, tubing or channels with at least two beams running perpendicular over the slip.

**Recommended Installation for boats up to 12,000 lbs.**

\* Boat Hoist USA does not sell a "kit" but will suggest a list of equipment that may or may not work in your particular situation. Ultimately it is up to the end user to identify and purchase the equipment needed and properly install the equipment for the lift to operate as intended. Any installation methods that contradict the intended design purpose of the individual parts and goes against the suggestions and guides in this pack, will reduce rated lifting capacities and could cause certain components in the lift to fail. Boat Hoist USA is not responsible for lift or structure design and is not responsible for any installation of equipment. Improper use of any equipment supplied by Boat Hoist USA will void all warranties to the end user.

# Boat Hoist USA Guide to Overhead Lifts

The flat plate hoist overhead lift system is the most cost effective method to get your boat out of the water. Keep in mind that each structure and installation method is unique to your application and boat being lifted. The following are common guidelines that all overhead lift systems must follow to properly and safely lift the boat.

- Check the weight of your load versus the lift capacity of the hoist. When calculating the load, don't forget the weight of the boat, fuel, boating gear, cradle, etc.
- Make sure you have enough voltage to lift your boat.
- Never weld a hoist to the structure.
- Mount the hoist at the end of the pipe.
- Only use two bolts to mount the hoist to the joist.
- Always grease the hoist before use and at least twice a year.
- The drive pipe needs to be perpendicular to the hoist and should slide easily within the hoist sleeve.
- Always support the pipe on each side of the lifting point and every ten feet with pipe supports.
- Always use the proper size of 7x19 Aircraft Cable to lift your boat.
- Proper cable attachment to the pipe is important.
- Cables need to be perpendicular to pipe (See Figure 2).
- Make sure cable is winding off opposite sides of the pipe (See Figure 1).
- Make sure cable clamps are attached to the cable correctly with the saddle side of the clamp on the un-cut side of the cable.
- Always hang strap hangers at a 45 degree angle to the boat (See Figure 2).
- Cable winders are optional. They increase the life of the cable, but decrease the lifting capacity of the hoist.
- Permanently mount the switch with the cable coming out the bottom of the switch. This will eliminate water penetration.

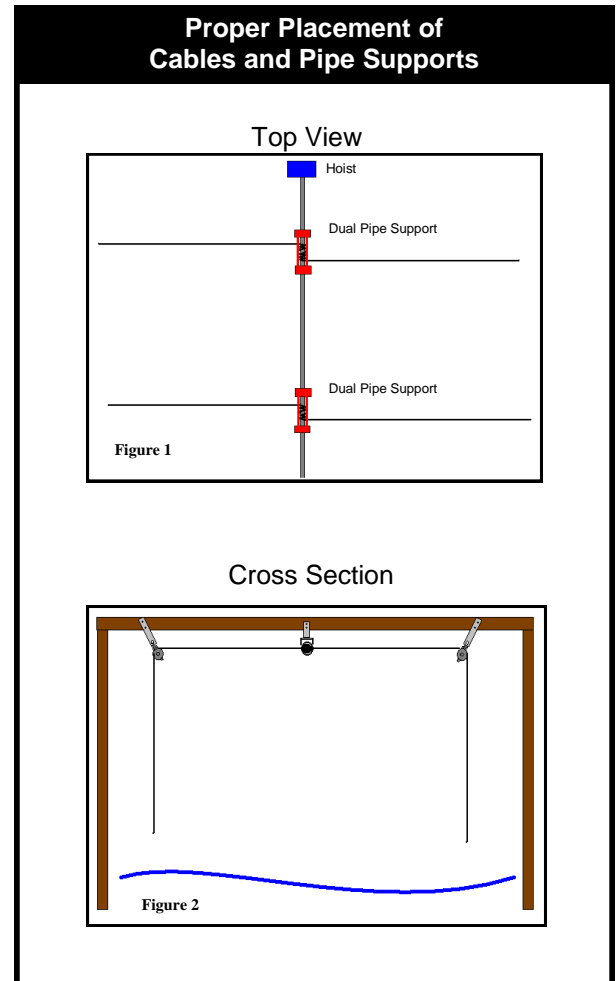

## A word to the end user:

While there are many notable and qualified professional lift installers, there are also many nonqualified installers. There is no governing or licensing agency that regulates the installation of lifts. Please take a moment to familiarize yourself with the basics of a lift and its design, and then check the installation of your lift.



Customer Service  
Monday thru Friday 8:00am-5:00pm CT.

**800-259-8715**

On-line Product Support

**www.bh-usa.com**

# Wood Construction Using 3 Overhead Joists

A common construction method where the boat house has two joists that are larger or doubled to carry the weight of the boat.

Boat Hoist USA considers this type of overhead installation a good option.

## Recommended Parts List

1. One Boat Hoist USA flat plate hoist
2. Two dual pipe supports for wood #700055
3. Four 3" or 4" blocks #700027 or 700028
4. Four 12" strap hangers Item #700038
5. Min 80-100' of 1/4" 7 x 19 aircraft cable #700071
6. Eight cable clamps #700103
7. Four cable thimbles #700133
8. Two polyester slings or one boat cradle
9. Four 10lb weights #700152 (if using slings)
10. Two cable winders #700149\* (optional)
11. Complete fastener pack

\* Cable winders are optional. They increase the life of the cable, but decrease the lifting capacity of the hoist up to 20%.



Mount the Boat Hoist USA hoist to the joist that will not be supporting the blocks. The hoist and pipe supports should be mounted in the center of the slip. See Figure 1. Use only two holes (not all four) to mount the hoist to the joist.

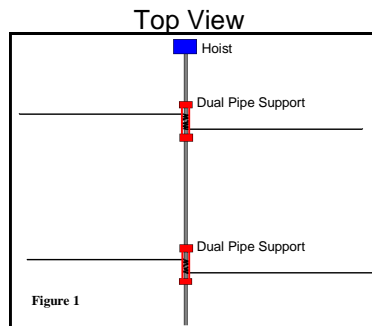

The strap hangers need to be mounted on the joist at a 45 degree angle toward the boat. See Figure 2. The block hangs at the end of the strap hanger and should be directly above the lift point on the cradle or sling. See Figure 3.

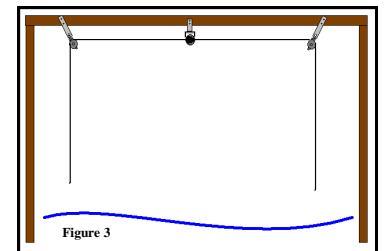
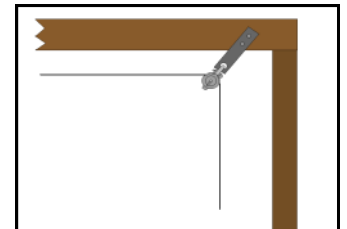

Recommended Joist Spacing: 10' to 12' apart.

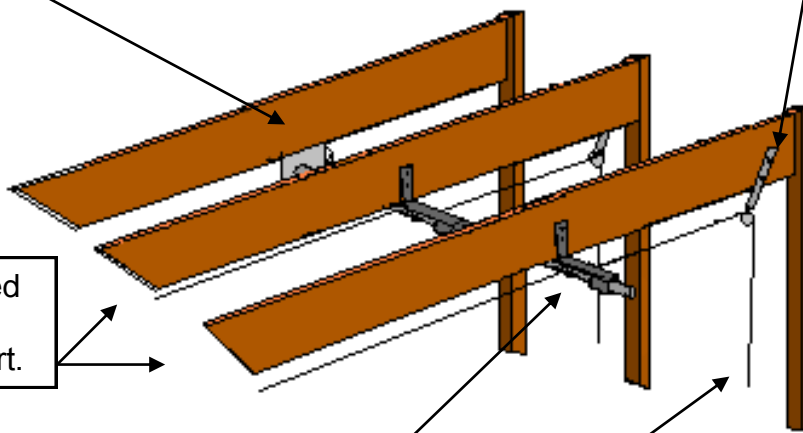

The dual pipe supports are designed to mount in the center directly under a joist. This will allow the cable to line up with the blocks.

Use one section of cable for the front and one for the back. Drill a hole in the pipe and run the cable through. Cables need to run perpendicular to pipe, not at an angle.

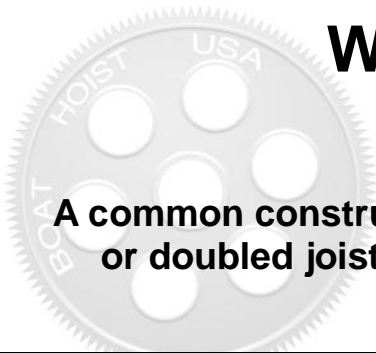

# Wood Construction With No Dedicated Lifting Joists

A common construction method where the structure does not have two larger or doubled joists for the lift, but has standard 2 x 6 or 2 x 8 floor joists at 16" or 24" centers.

## Recommended Parts List

1. A Boat Hoist USA flat plate hoist
2. Three basic pipe supports for wood #700053
3. Four 3" or 4" blocks #700027 or 700028
4. Four 12" strap hangers #700038
5. Min 80-100' 1/4" 7 x 19 aircraft cable #700071
6. Eight cable clamps #700103
7. Four cable thimbles #700133
8. Two polyester slings or one boat cradle
9. Four 10lb weights #700152 (if using slings)
10. Two cable winders #700149\* (optional)
11. Complete fastener pack

\* Cable winders are optional. They increase the life of the cable, but decrease the lifting capacity of the hoist up to 20%.

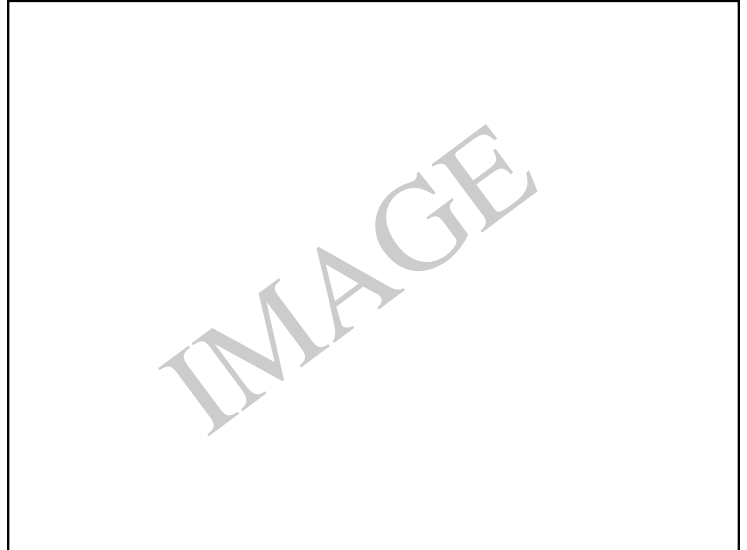

Mount the Boat Hoist USA hoist to the joist not being used to hold the blocks or pipe supports. The hoist and pipe supports should be mounted in the center of the slip. Use only two holes (not all four) to mount the hoist to the joist.

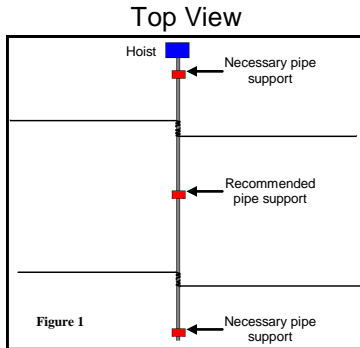

The strap hangers need to be mounted on the joist at a 45 degree angle toward the boat. See Figure 2. The block hangs at the end and should be directly above the lift point on the cradle or sling. See Figure 3.

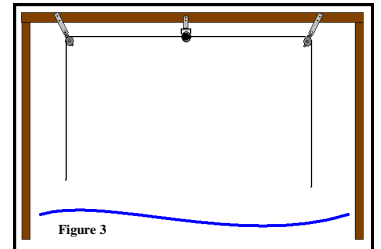
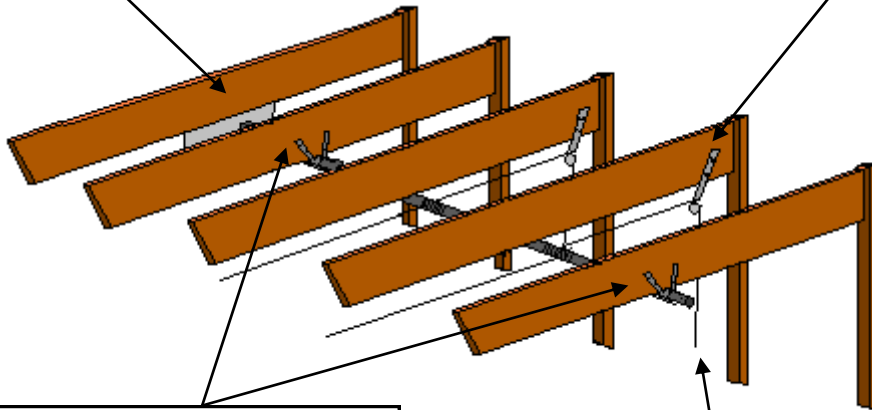
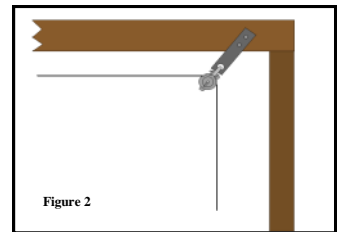

The pipe supports are designed to mount on joists that are not supporting the blocks and strap hangers. You must mount one pipe support before and after the lifting point. We also recommend using additional pipe supports every ten feet. See Figure 1.

Use one section of cable for the front and one for the back. Drill a hole in the pipe and run the cable through. Cables need to run perpendicular to pipe, not at an angle.

# Wood Construction With Twin Motors For Boats Exceeding 8500 lbs

Installing two independent hoists on a wood structure allowing to straight line lift boats exceeding 8500 lbs.

## Recommended Parts List

1. One Boat Hoist USA flat plate hoist
2. One Boat Hoist USA flat plate hoist wired with 45' of control cable
3. Four dual pipe supports for wood #700055
4. Min 80-100' 1/4" 7 x 19 aircraft cable #700071
5. Eight cable clamps #700103
6. Four cable thimbles #700133
7. Two polyester slings or one boat cradle
8. Four 10lb weights #700152 (if using slings)
9. Four cable winders #700148\* (optional)
10. One GEM GR2 Remote #400013 (optional)
11. Complete fastener pack

\* Cable winders are optional. They increase the life of the cable, but decrease the lifting capacity of the hoist up to 20%.

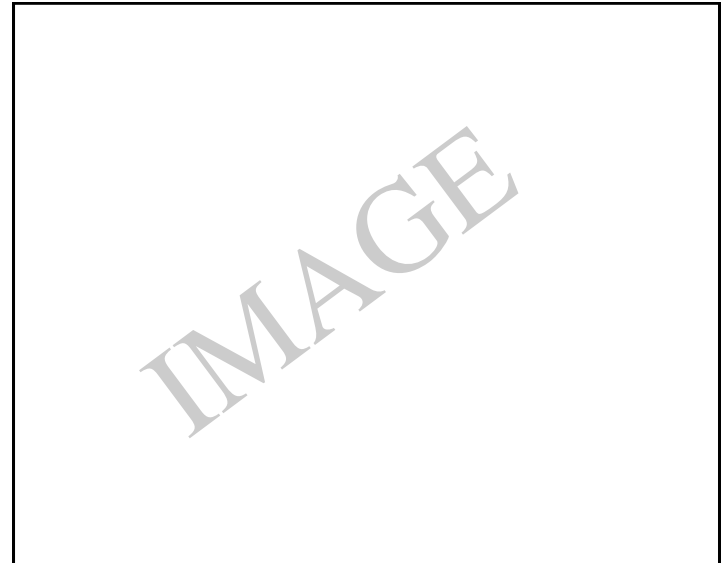

Mount the Boat Hoist USA hoists to joists not being used to support the blocks or pipe supports. Mount the hoists on both sides of the boat running parallel to the boat. This ensures that each hoist will be sharing the load.

The dual pipe supports should be mounted directly above each lifting point on the sling or cradle. The dual pipe supports are designed to mount in the center directly under a joist.

Recommended Joist Spacing: 10' to 12' apart.

Two motors on one lift require more voltage than the traditional one motor lifts. For wire requirements, refer to the chart on page 8 of the Boat Hoist USA Equipment Guide.

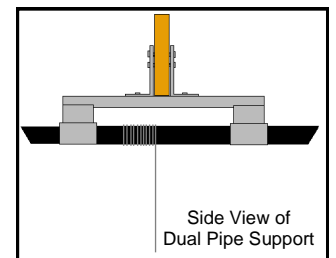
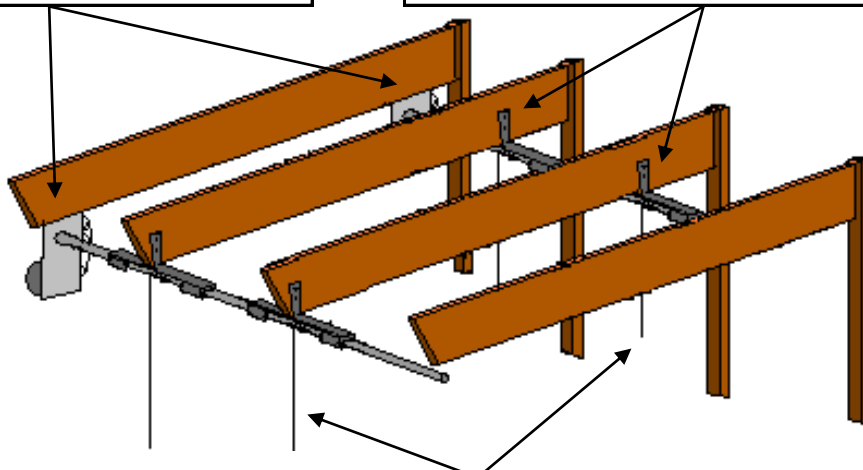

Having one hoist wired with extra control cable allows you to mount both standard switches side by side. Do not attempt to wire both hoists to one drum switch. Instead, we recommend installing a GR2 GEM Remote. The GR2 will allow you to operate 2 motors with one remote.

Each lifting point will require its own length of cable. Find the center of each dual pipe support and drill a hole in the pipe. Run the end of the cable through the hole, and then feed it through the shaft of the pipe and out the end. Attach a cable clamp, and then pull the cable back through pipe.

In this application the dual pipe supports will be load bearing. Each pipe support must be well greased to help eliminate unnecessary friction.

# Wood Construction Using 3 Overhead Joists With Hoist & Pipe Mounted To One Side

Recommended Boats weighing up to 4500 lbs.

## Recommended Parts List

1. One Boat Hoist USA flat plate hoist
2. Two dual pipe supports for wood # 700055
3. Two 12" strap hangers # 700038
4. Two 3" 1.5 ton blocks # 700027
5. Min 80-100' min 1/4" 7 x 19 aircraft cable #700071
6. Eight cable clamps #700103
7. Four cable thimbles #700133
8. Two polyester slings or boat cradle
9. Four 10lb weights # 700152 (if using slings)
10. Four cable winders # 700149\* (optional)
11. Complete fastener pack

\* Cable winders are optional. They increase the life of the cable, but decrease the lifting capacity of the hoist up to 20%.

IMAGE

Mount the Boat Hoist USA hoist to the joist not being used to hold the blocks or pipe supports. Hoist and pipe supports need to be aligned directly above the lifting points on one side of your boat. Use only two holes to mount the hoist.

Recommended Joist Spacing: 10' to 12' apart.

The strap hangers should not be mounted on the same joists that pipe supports are mounted on. The strap hangers need to be at a 45 degree angle toward the boat. See Figure 2. The block hangs at the end and needs to be directly above the lift point on the cradle or sling.

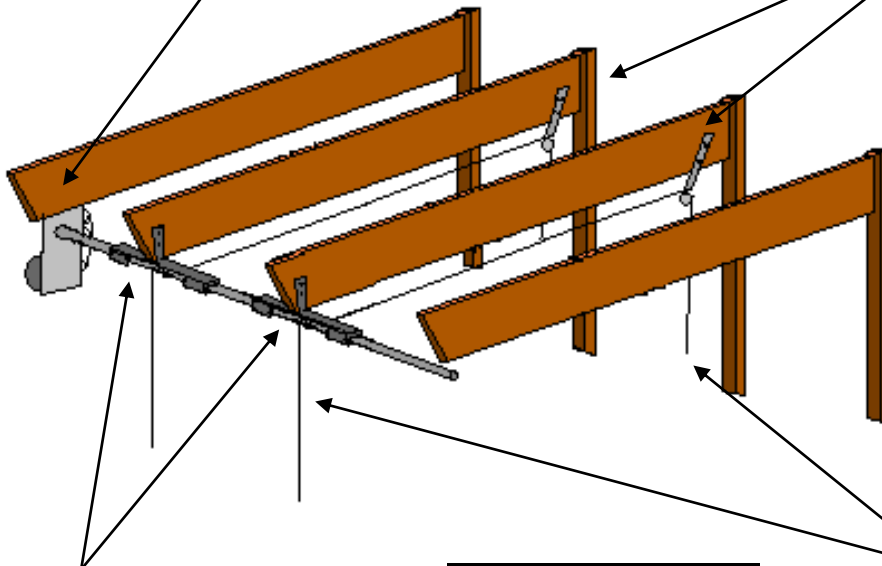

In this application the dual pipe supports will be load bearing. Each pipe support must be well greased to help eliminate unnecessary friction.

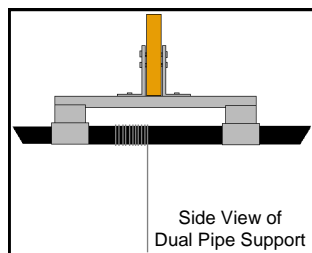

Use one section of cable for the front and one for the back. Drill a hole in the pipe and run the cable through. Cables need to run perpendicular to pipe, not at an angle. See Figure 2.

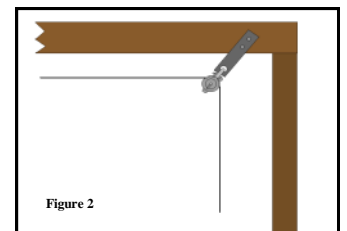

# Steel Top Structure On 4 Pilings Using Two Cross Beams For The Lift

Recommended for boats up to 8500 lbs

## Recommended Parts List

1. One Boat Hoist USA flat plate hoist
2. One BHUSA hoist hanger for steel #700059-700063\*
3. One dual pipe support for steel #700232\*
4. Four galvanized I-beam clamps #700039-700043\*
5. Four 3" 1.5 ton or 4" 3 ton blocks #700027 or 700028
6. Min 80-100' 1/4" 7 x 19 aircraft cable #700071
7. Eight cable clamps #700103
8. Four cable thimbles #700133
9. Two polyester slings or boat cradle
10. Four 10lb weights # 700152 (if using slings)
11. Four cable winders # 700149\*\* (optional)
12. Complete fastener pack

\* Customer must specify the size of beams they are using.

\*\* Cable winders are optional. They increase the life of the cable, but decrease the lifting capacity of the hoist up to 20%.

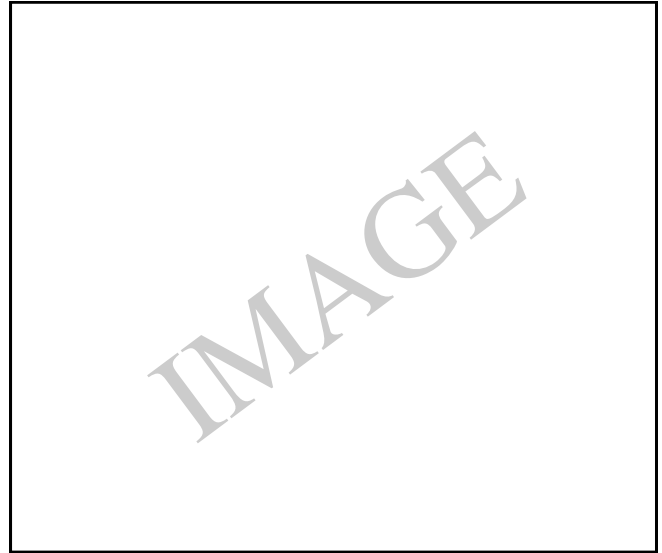

The steel hoist hanger (Picture 2) is designed to properly hang the hoist and at the same time, support the pipe. The hoist hanger should be mounted on the same beam as the first lifting point. The hoist hanger is designed to be used with the dual pipe support for steel (Picture 1) only. It will not align with other supports. Do not attempt to use the hoist hanger in a side mount application; the uneven torque and leverage can damage the hoist hanger and will void warranty.

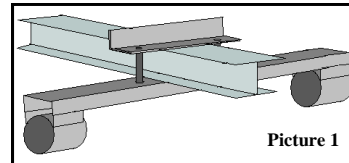

Picture 1

Recommended Beam Spacing: 10' to 12' apart.

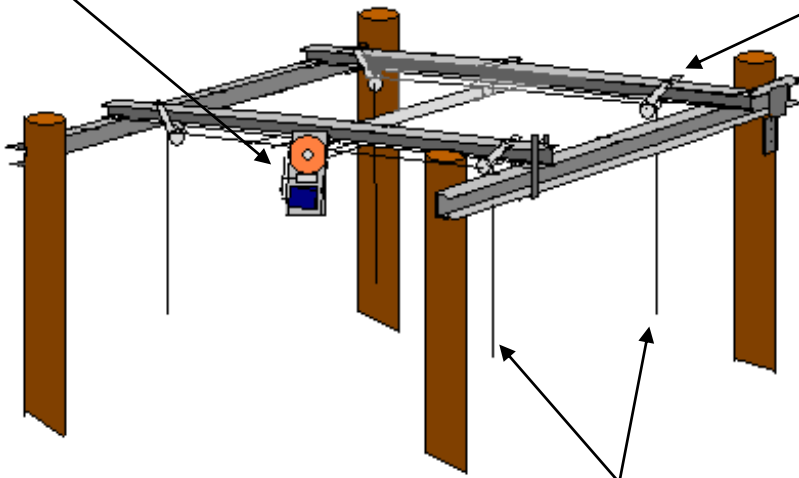

Angle the galvanized I-beam clamps (Picture 3) towards the boat at a 45 degree angle. This will eliminate unnecessary torque and help the clamps from sliding on the I-beams while being used on extreme loads. Clamps can be used on I-beams, channels or Tubing.

Do not allow any more than 10 feet between the hoist hanger and the dual pipe support. Unsupported sections of the pipe will "bow" and cause the unit to bind.

Use one section of cable for the front and one for the back. Drill a hole in the pipe and run the cable through. Cables need to run perpendicular to pipe, not at an angle.

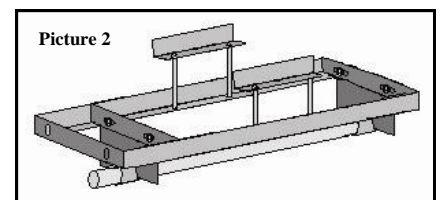

Picture 2

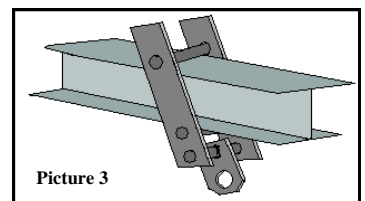

Picture 3

# Steel Top Structure On 4 Pilings Using Two Cross Beams For Twin Motors

Recommended for boats up to 12,000 lbs

## Recommended Parts List

1. Two Boat Hoist USA flat plate hoists
2. Two hoist hangers for steel #700059-700063\*
3. Two dual pipe supports for steel #700232\*
4. Min 80-100' 1/4" 7 x 19 aircraft cable #700071
5. Eight cable clamps #700103
6. Four cable thimbles #700133
7. Two polyester slings or boat cradle
8. Four 10lb weights #700152 (if using slings)
9. Four cable winders #700148\*\* (optional)
10. Complete fastener pack

\* Customer must specify the size of beams they are using.

\*\* Cable winders are optional. They increase the life of the cable, but decrease the lifting capacity of the hoist up to 20%.

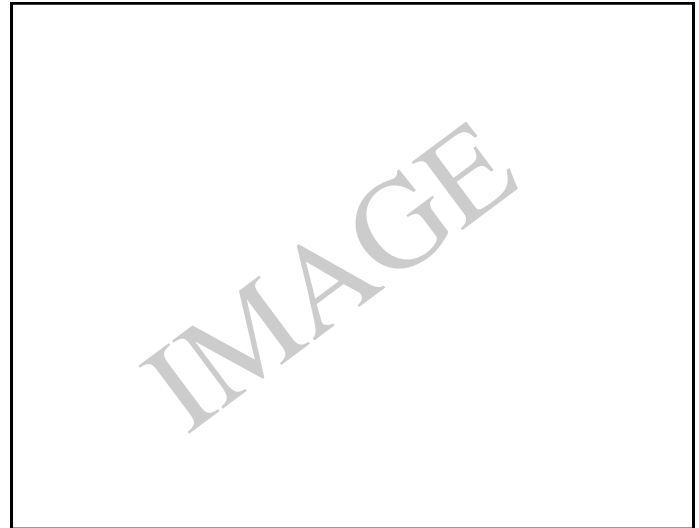

The steel hoist hanger (Picture 2) is designed to properly hang the hoist and at the same time, support the pipe. The hoist hanger should be mounted on the same beam as the first lifting point. The hoist hanger is designed to be used with the dual pipe support for steel (Picture 1) only. It will not align with other supports. Do not attempt to use the hoist hanger in a side mount application; the uneven torque and leverage can damage the hoist hanger and will void warranty.

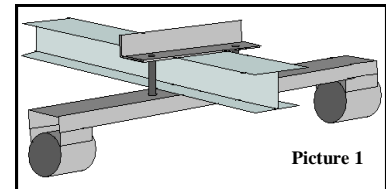

The dual pipe support for steel mounting (Picture 1) is specifically designed to line up with the BHUSA hoist hanger (Picture 2) and will not work unless used with the steel hoist hanger.

Each lifting point will require its own length of cable. Find the center of each dual pipe support and drill a hole in one side of the pipe. Run the end of the cable through the hole, and then feed it through the shaft of the pipe and out the end. Attach a cable clamp, and then pull the cable back through pipe.

Do not allow any more than 12 ft between the hoist hanger and the dual pipe support. The unsupported section of pipe will "bow" and cause the unit to bind.

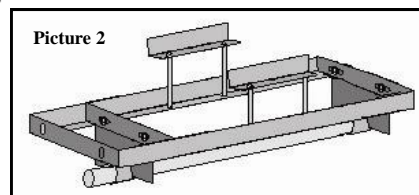

# Boat Hoist USA Cradle Installation

Boat Hoist USA cradles come with the I-beams and angles for two bunks. Optional pieces include guide posts, guide post bumpers and cable savers. Wood for the bunks is not included.

The Boat Hoist USA galvanized boat cradles are designed to lift and store a boat on two bunk boards held by cables on the ends of each I-beam. The completely adjustable bunk board brackets allow the user to fit the bunk boards to the hull of the boat, allowing for the optimal pick up point on the hull. This also eliminates unneeded weight and stress of the lift by only using two structural beams.

